

Einbauplatte sendzimirverzinkt

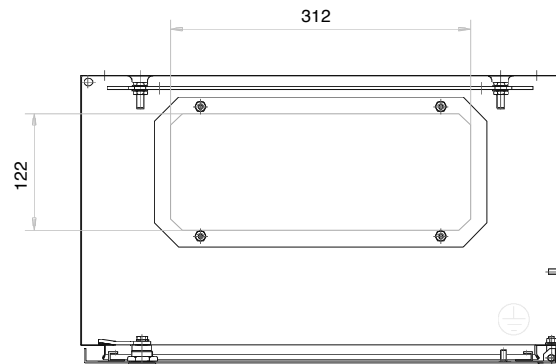

Blechstärke Gehäuse: 1,07 mm
 Einbauplatte: 2,00 mm
 Tr: 1,50 mm

Oberfläche: pulverlackiert RAL 7035

WB = Wandbefestigung ° 9
 LW = Lichte Weite

 Masse: Gewindebolzen M6 x 12

		Maßstab: 1:5		Gewicht:	
		CAD: C:00055492.SZN			
		Datum	Name		
	Bearb.	11.07.2007	MolnarW		
	Gepr.				
	Norm				
		hawa Fertigungs GmbH			
		Industriestraße 12 D-88489 Wain			
		0331-5050-30-17			Blatt
Zust.	Änderung	Datum	Name Urspr.	Ers. f.:	Ers. d.: